

PRODUCT DATA SHEET

Black Square Riser Kit

Product Code: BLACK003ORB



SCUDO
BEAUTIFUL BATHROOMS

0330 124 7290

sales@scudo.co.uk - www.scudo.co.uk

Scudo is the trading name of Harrison Bathrooms Ltd. Whilst we endeavour to ensure that the product information is accurate we accept no liability for any information given. All images are for illustration purposes only. Product images and specification are subject to change. Measurement are in millimetres and are nominal.

Product Measurements	
Product Weight:	0.6kg
Product Width:	26mm
Product Height:	610mm
Product Depth:	57.5mm
Product Length:	N/A
Product Transportation	
Barcode:	5060500644239
Country of Origin:	China
Comodity Code:	3924900000
Primary Packed Measurements	
Packaged Weight:	0.8kg
Packaged Length:	610mm
Packaged Width:	150mm
Packaged Height:	75mm
Packaging Weight	
Card:	0.19kg
Paper:	N/A
Wood:	N/A
Plastic:	0.008kg
General Information	
Construction Material:	Plastic/Stainless Steel
Installation Type:	Wall Mounted
Colour/Finish:	Black
Showering Specification	
Anti-Scald:	N/a
Shower Diverter Function:	No
Number of Outlets:	1
Thermostatic Temp Control:	N/a
Cool Touch:	No
Shower Handset Function:	1
Minimum Working Pressure:	0.5 bar
Maximum Working Pressure:	5 bar
Shape:	Square
Pipe Centres:	N/a
Inlet Connection:	1/2 BSP
Outlet Connection:	1/2 BSP
Adjustable:	No
Adjustment:	N/A
Handle Type:	Button
Flow Rates	
0.2bar (l/min)	N/A
0.5bar (l/min)	N/A
1bar (l/min)	N/A
2bar (l/min)	N/A
3bar (l/min)	N/A
Compliance DOP	

Spare Codes & Cartridge Type	
Valve / Cartridge Type	N/A
Cartridge Spare Code:	spares@harrisonbathrooms.com

For Part G Building regulations, compliance see flow regulator section of spec binder.

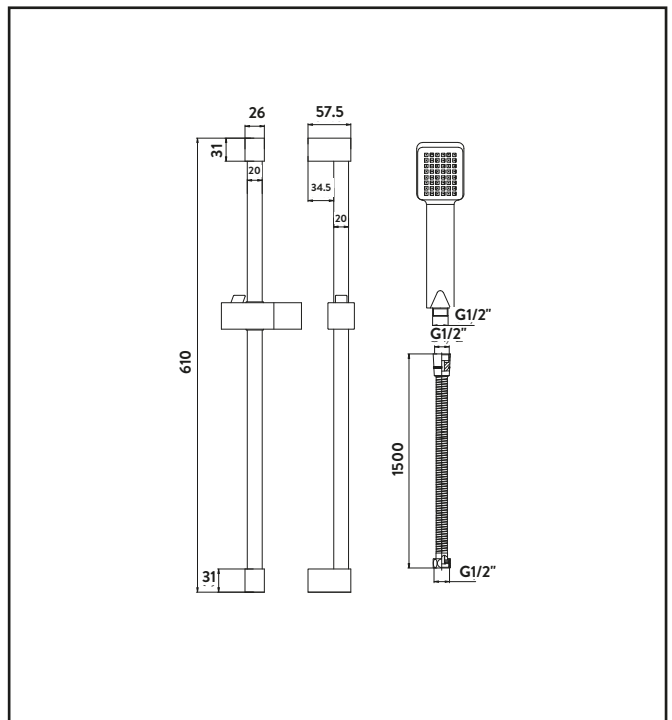

Dimensions
(measurements in mm)



LIFETIME GUARANTEE

We are confident in our products and we want our customer to be, we proudly give a lifetime guarantee on our taps and showers, further details can be found on our website