

BIFOLD DOOR

Porte pliante Zweiteilige tür Tweedelige deur

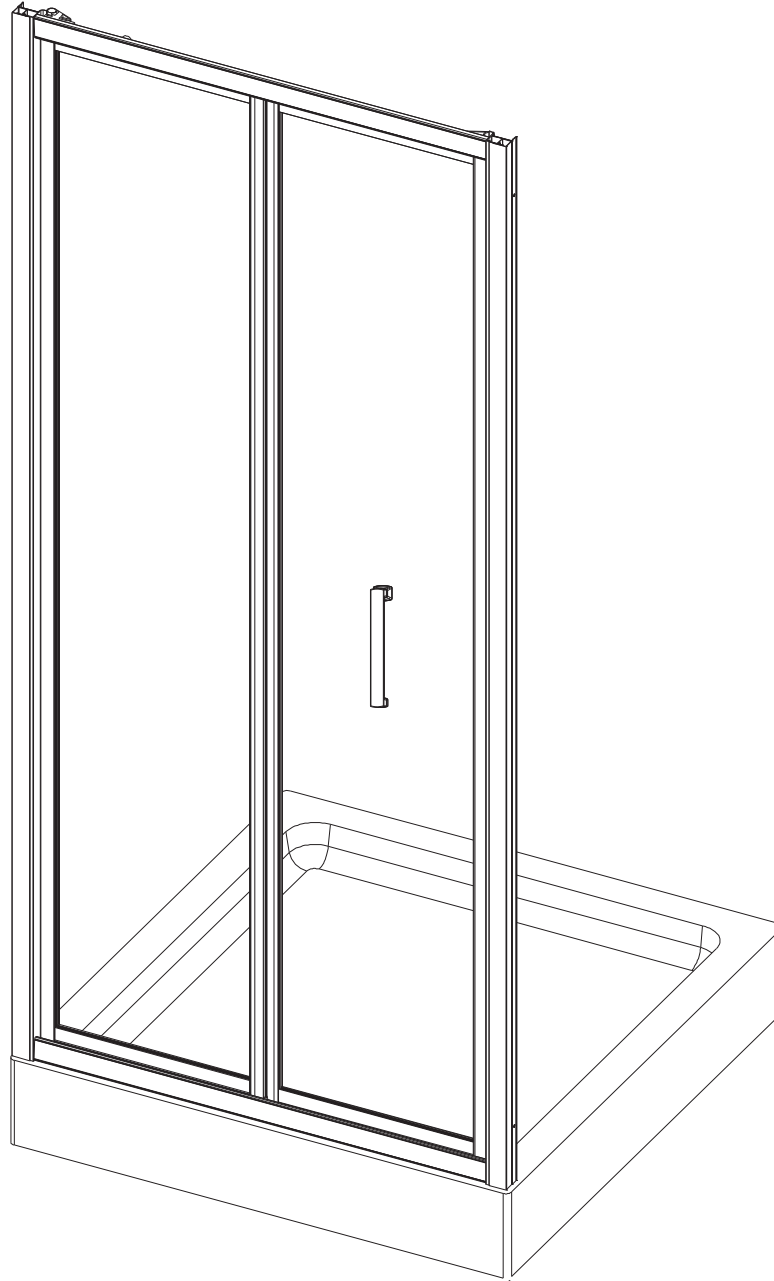

INSTALLATION GUIDE

Guide d'installation Installstionsanleitung Installatiehandleiding

ENGLISH

If you install the product in a way that differs from this manual this will void all guarantees. Before installation check that the product meets all your requirements and is not damaged. By proceeding with installation, you accept the condition of the product. The wall plugs supplied with the installation kit are for use in solid walls. Hollow or 'stud partition' walls will require alternative fixings. Please consult your local hardware supplier for the correct type.

FRANCAIS

Si vous installez le produit d'une manière différente de celle présentée dans ce manuel toutes les garanties seront invalidées. Contrôlez avant le placement si le produit répond à toutes vos exigences et n'est pas endommagé. En procédant au placement, vous acceptez l'état dans lequel se trouve le produit. Les fixations murales fournies avec le kit d'installation sont prévues pour des murs en dur. En cas de mur creux, vous devrez consulter votre magasin de bricolage afin d'utiliser un modèle adéquat.

NEDERLANDS

Indien u het product plaatst op een manier die afwijkt van deze handleiding vervalt alle garantie. Controleer voor plaatsing of het product aan al uw eisen voldoet en niet beschadigd is. Indien u overgaat tot plaatsing, aanvaardt u de staat waarin het product zich bevindt. De met de installatie kit meegeleverde pluggen zijn voor gebruik in massieve muren. Niet-massieve muren vereisen alternatieve bevestigingen. Raadpleeg uw lokale bouwmarkt voor het juiste type.

DEUTCH

Wenn Sie das Produkt nicht genau nach den Angaben in dieser Montageanleitung einbauen, verfällt die Garantie. Überprüfen Sie vor dem Einbau des Produkts, ob sämtliche Voraussetzungen erfüllt sind und das Produkt nicht beschädigt ist. Sobald Sie mit der Montage beginnen, sehen Sie, in welchem Zustand sich das Produkt befindet. Die mit dem Installationskit mitgelieferten Dübel sind für den Einsatz in festen Wänden. Nicht-feste Wände erfordern alternative Befestigungen. Bitte fragen Sie Ihren lokalen Baumarkt nach dem richtigen Typ.

Size Taille Größe Maat	Product code Code du produit Produkt-Code Productcode	Adjustment Ajustement Anpassung Aanpassing	Opening space Écartement de l'ouverture Öffnungsraum Openingsruimte
700	A0200A0	650-690	400
760	A0200B0	710-750	460
800	A0200C0	750-790	500
900	A0200D0	850-890	600

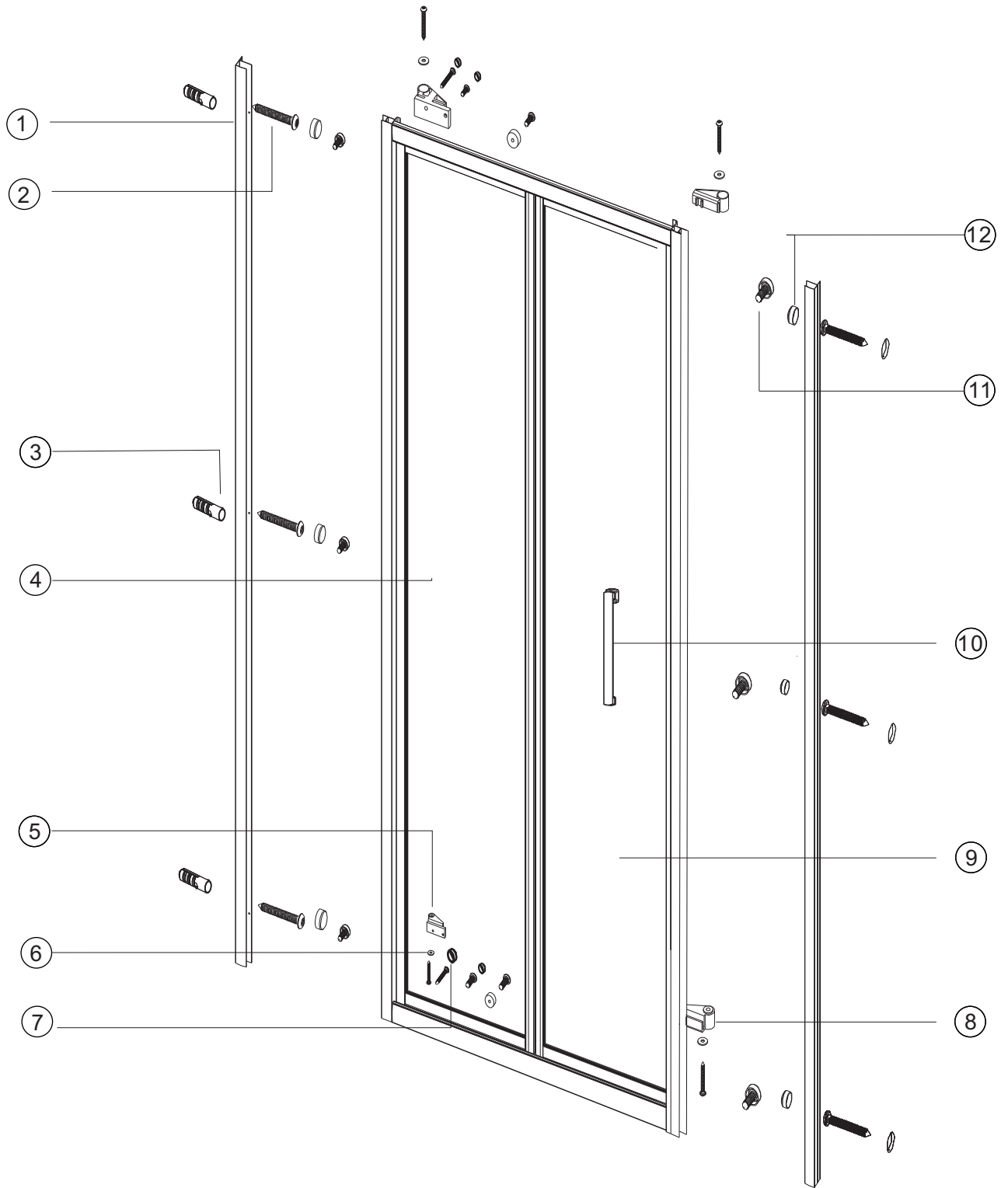

NO.	Qty	Part No.
1	2	A02S0020
2	6	2SY51
3	6	2SP12
4	1	A
5	2	2SS020 L/R
6	4	2SQF2&2SQF3

NO.	Qty	Part No.
7	4	2SS020A
8	2	2SS018 L/R
9	1	B
10	1	A02S0043
11	6	2SY50
12	12	C070

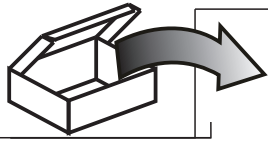

C070
x12

4x30mm

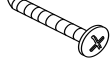

2SY51
x6

4x16mm



2SY50
x6



2SP12
x6

Ø3mm



C056
x1

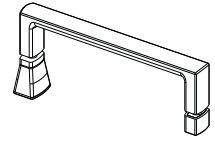

A02S0043
x1

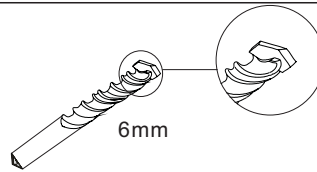
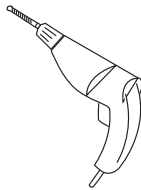
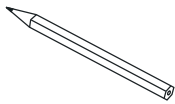

6mm

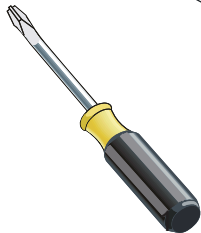
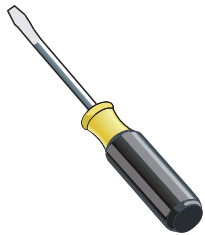

PH2

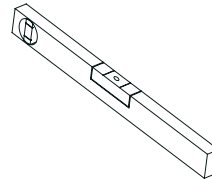
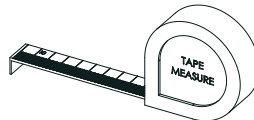

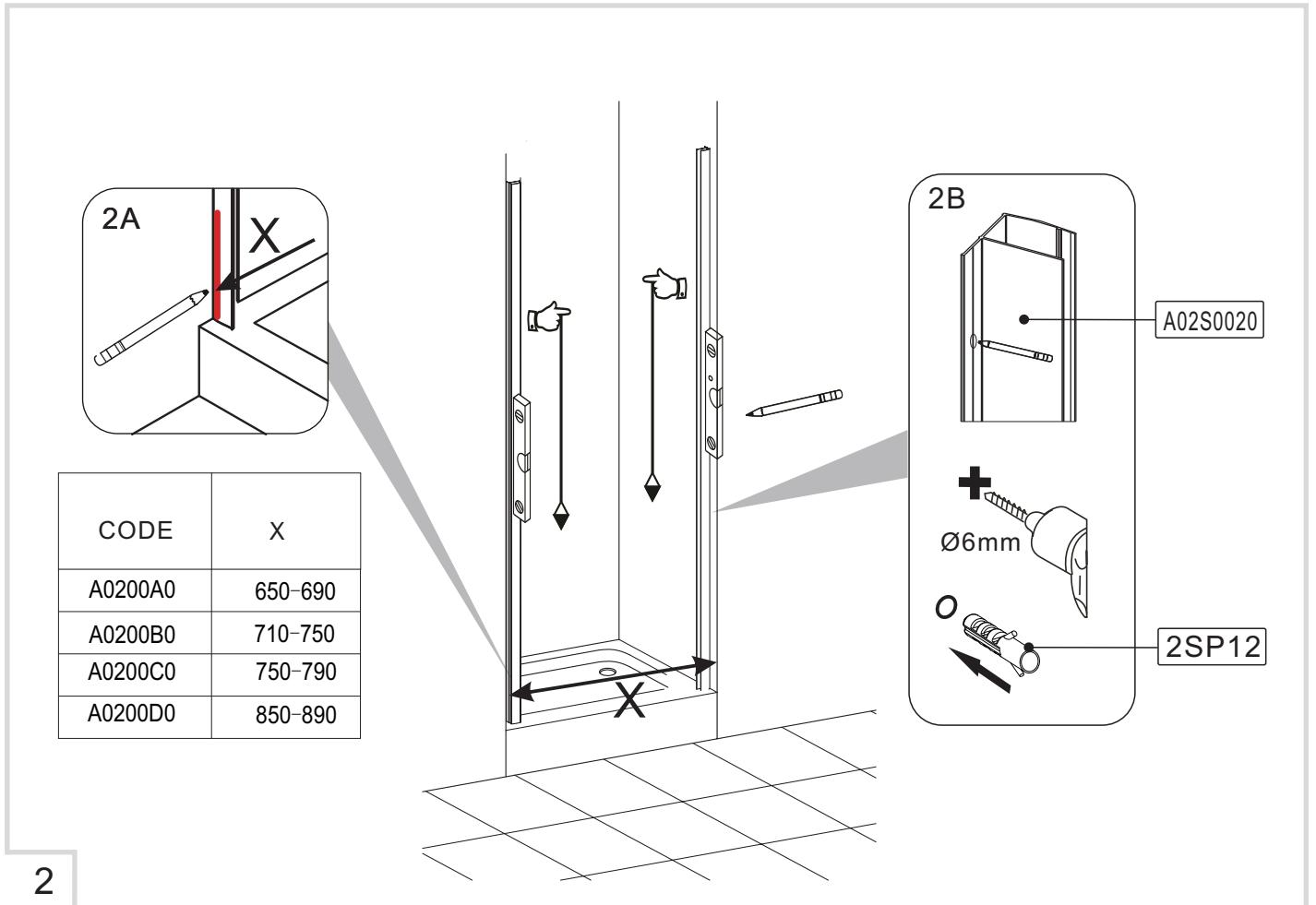
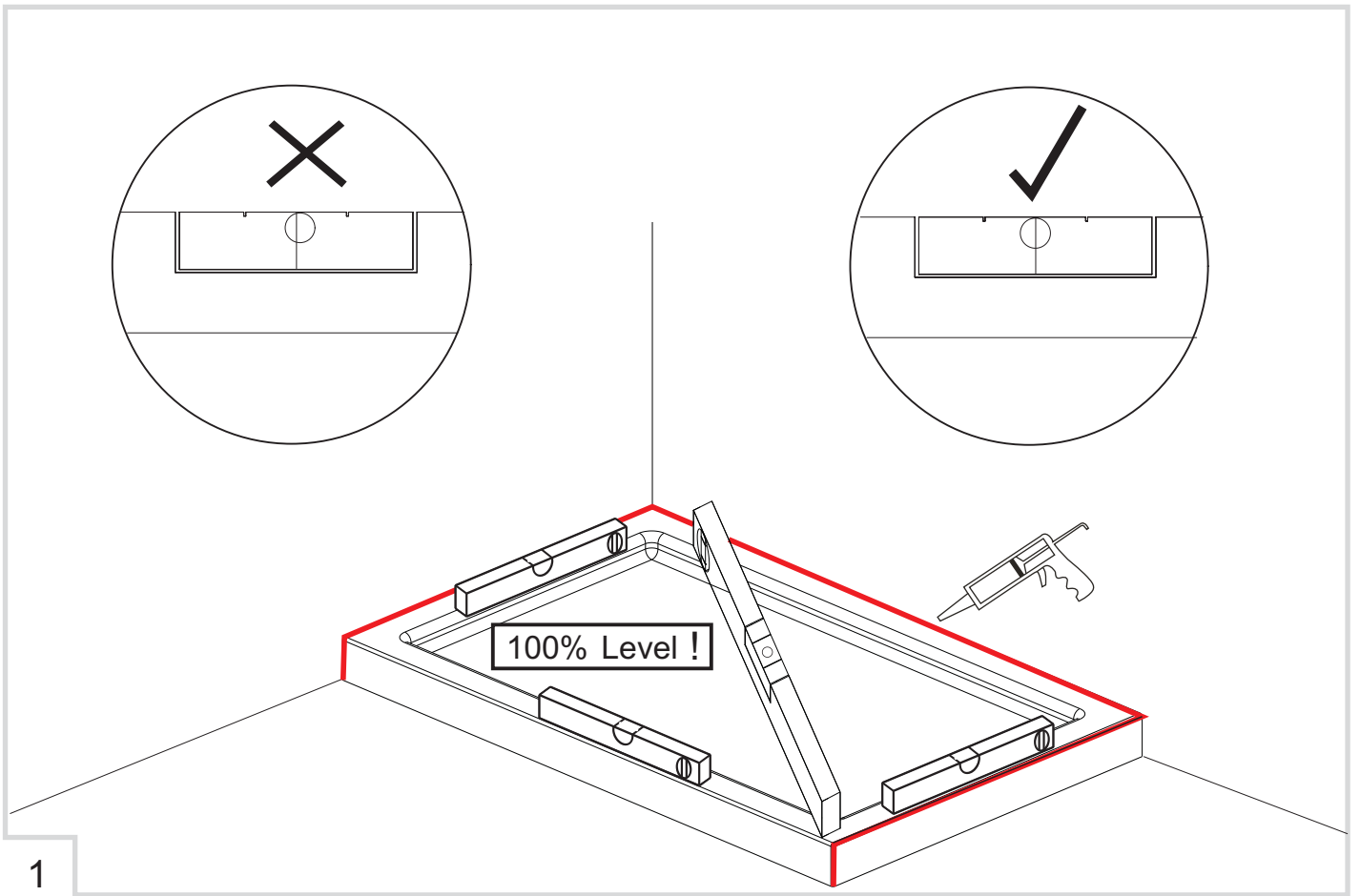

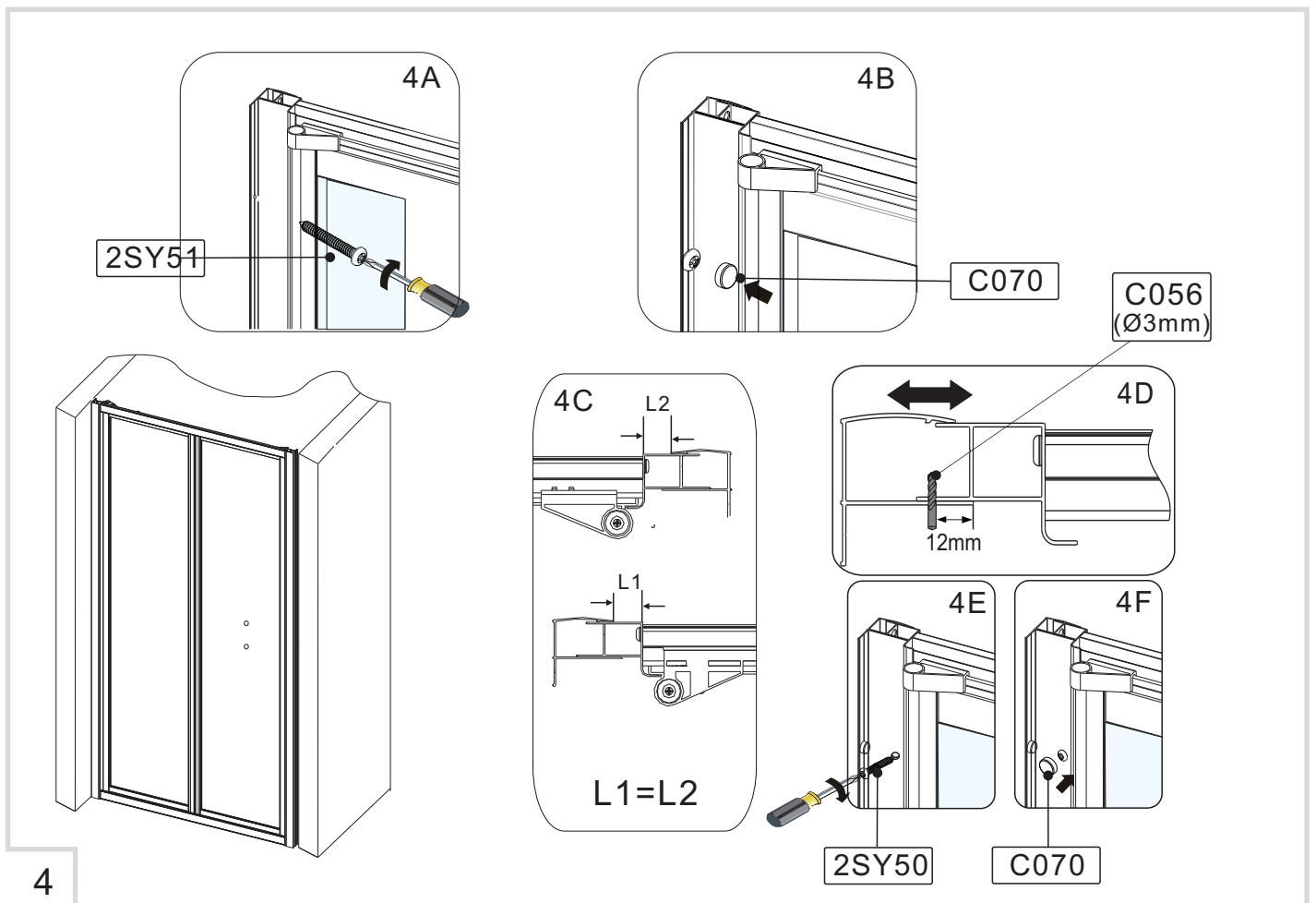
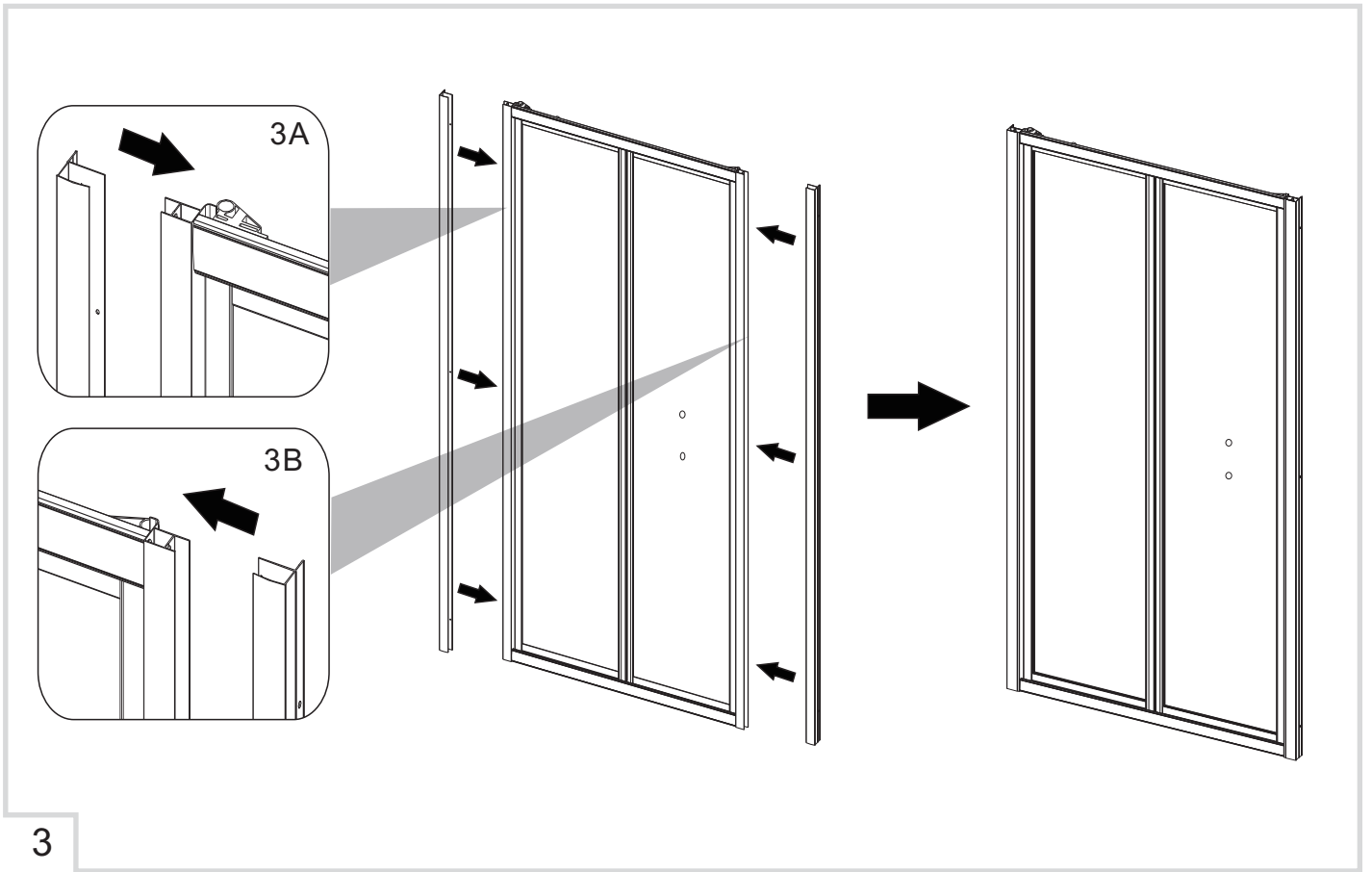

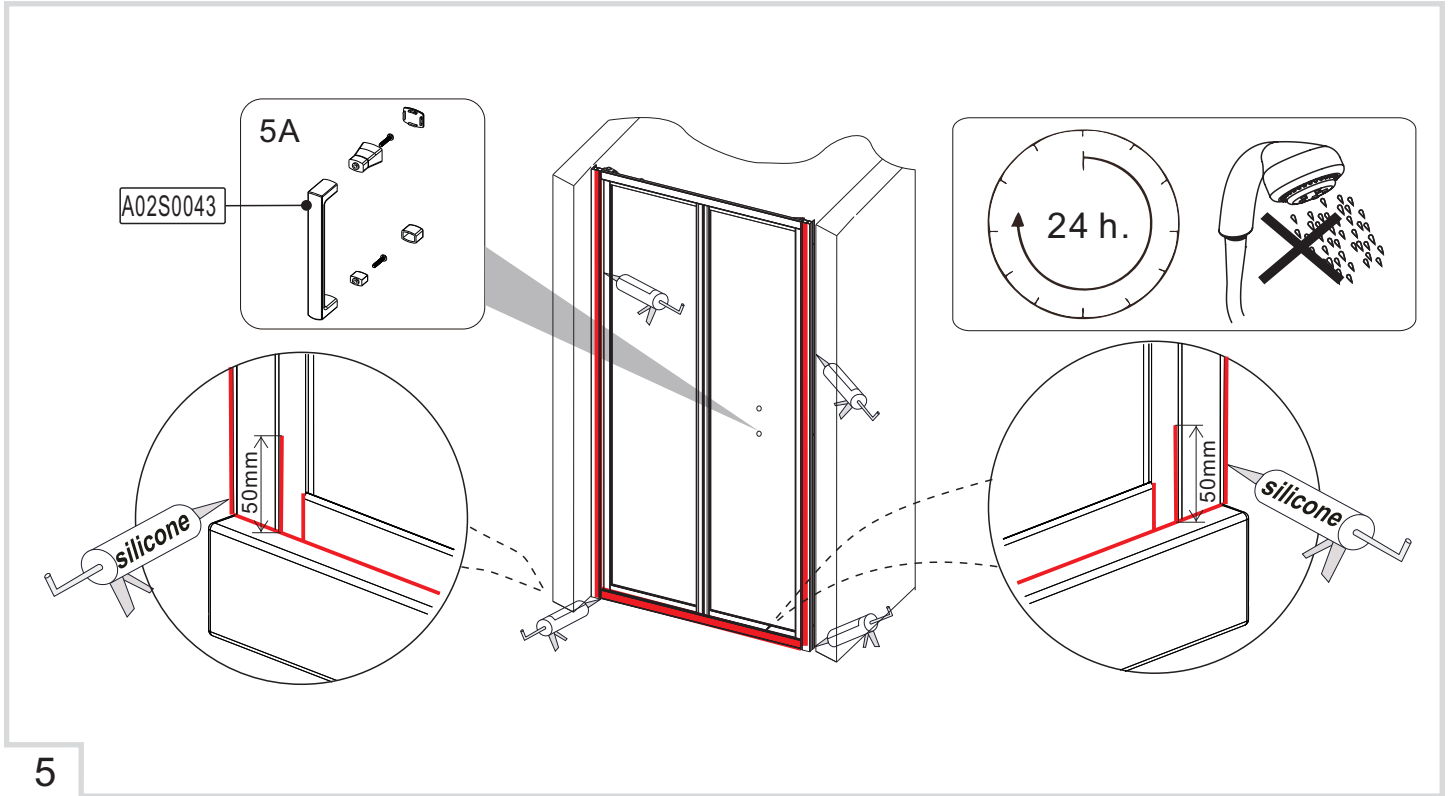

5

CE

Mertyn Industries Ltd (MER09)
Purcellsinch, Kilkenny, IRL.

13

EN 14428

Shower enclosures with aluminium
profiles and safety glass

Cleanability : Pass

Impact resistance/
shatter properties : Pass

Durability : Pass

6